

I B@GGC H:9FK 69 GD97 ÷ 98. 8 A 9BGC BG5F9 B A @A 9HFG G F: 5 7 9: B 6<. HC @F5B7 9G * @B95F. **5B: 1 @5F.			: B 6<.			8 96I F 5B8 6F95? G<5FD 98: 9G			8C BC HG7 5 @8F5K B;		F9J 6C B	
B5A 9			G: B5H F9			85H9			6["5 bhc b'GWc hY]hbYf; a V< Dfc Y_h J ?I D& HfY. 6fYa gi Zh5XUdhYf 6YgWfY]i b[. N gJa a YbVUi 'J ?I D& 5(
8F5K B			GWUi YF5"			&+"\$&"&\$\$,						
7 < ? 8												
5DDJ 8												
A ::												
E "5						A 5Hf 5@						
						b]W hXYZ'						
						K 9: <H'			A UegUV. %%			
									6Uth%#%\$			

Bf"	6 YnY]W bi b[5 fh_Y 'Bf"	Gh W
F	S\^ { • & @æ à ^	Jí FEFÉ	F
G	Ü^&c • Á & @ \ c ^ • & @ • • Ä S ~]] } * Ä SÖE	Jí FEFÉ	F
H	S\^ { ä *	Jí FEFÉ	F

5
6
7

5
6
7

8

%

&

K 9: <H'

A UegUV. %%

6Uth%#%\$

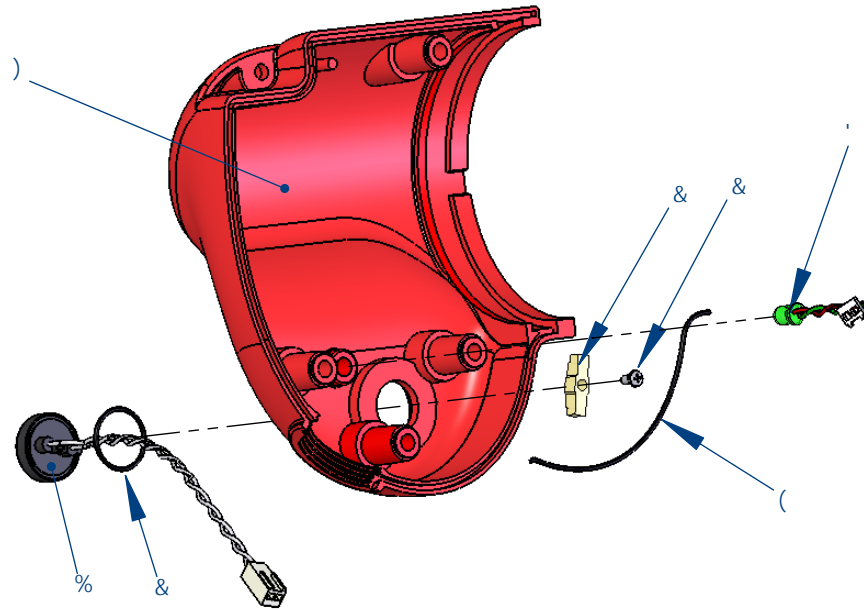
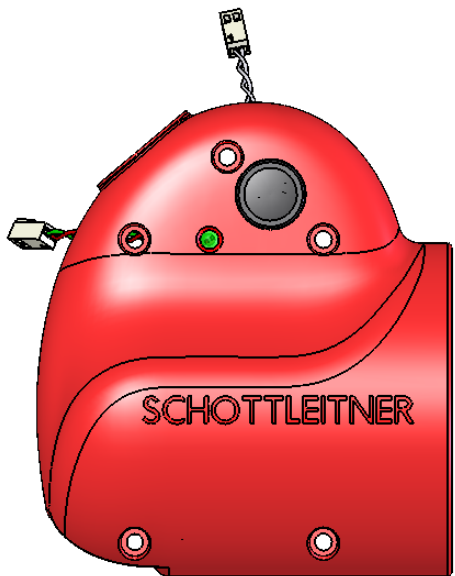
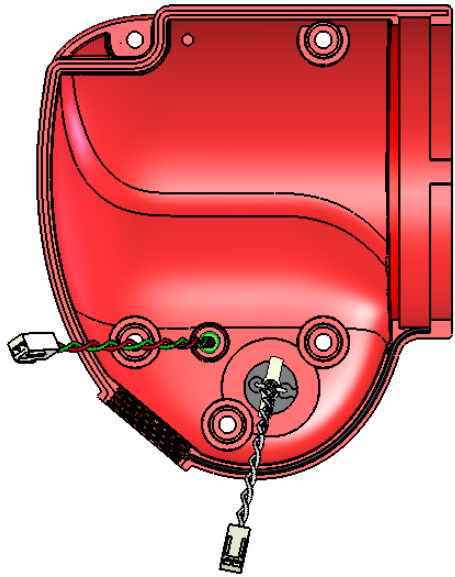

Bf'	6YnY]Mbi b[5fh_Y`Bf'	Gf`W_
%	A 7 G% `8fi W_HUgYf'a]h?UVY`	-%%+\$\$\$	%
&	A 7 G% `8]Mhi b[ggUhm'fl !h["t	-%%+\$\$\$%	%
'	@98 `a]h?UVY`	-)%\$%\$'	%
(8]Mhg]Mbi fX%,) a a	-' % %\$%	%
)	; Y\} i gYgMUY`fY]Mhg	-)%\$%\$(%

I B@GGC H:9FK -69 GD97 ÷98. 8-A 9BGC BG5F9-B A @@A 9HFG G F: 57 9: B-G<. H: @F 5B7 9G " @B 95 F. "5B: I @5 F.			: B-G<.	896I F 5B8` 6F95? G<5FD' 98: 9G	8C`BCHG75@8F5K`B: F9J GCB
B5A 9			G= B5H F9	85H9	Dfc`Y_h
8F5K B	GM]Ui Yf5"		&+"\$&"&\$\$,		J ?I D&
7 <?fB					HfY`
5DDJ B					; Y\} i gYgMUY`fY]Mhg
A ::					6YgM]Y]i b[.
E "5			A 5HfF 5@		Ni g]a a YbVUi `J ?I D&
			b]M]hXYZ'		5(
			K 9= <H'		A UEgtUV. %%
					6Uth' #%%\$

YjM YfN gJa a YbVUi
5ž6

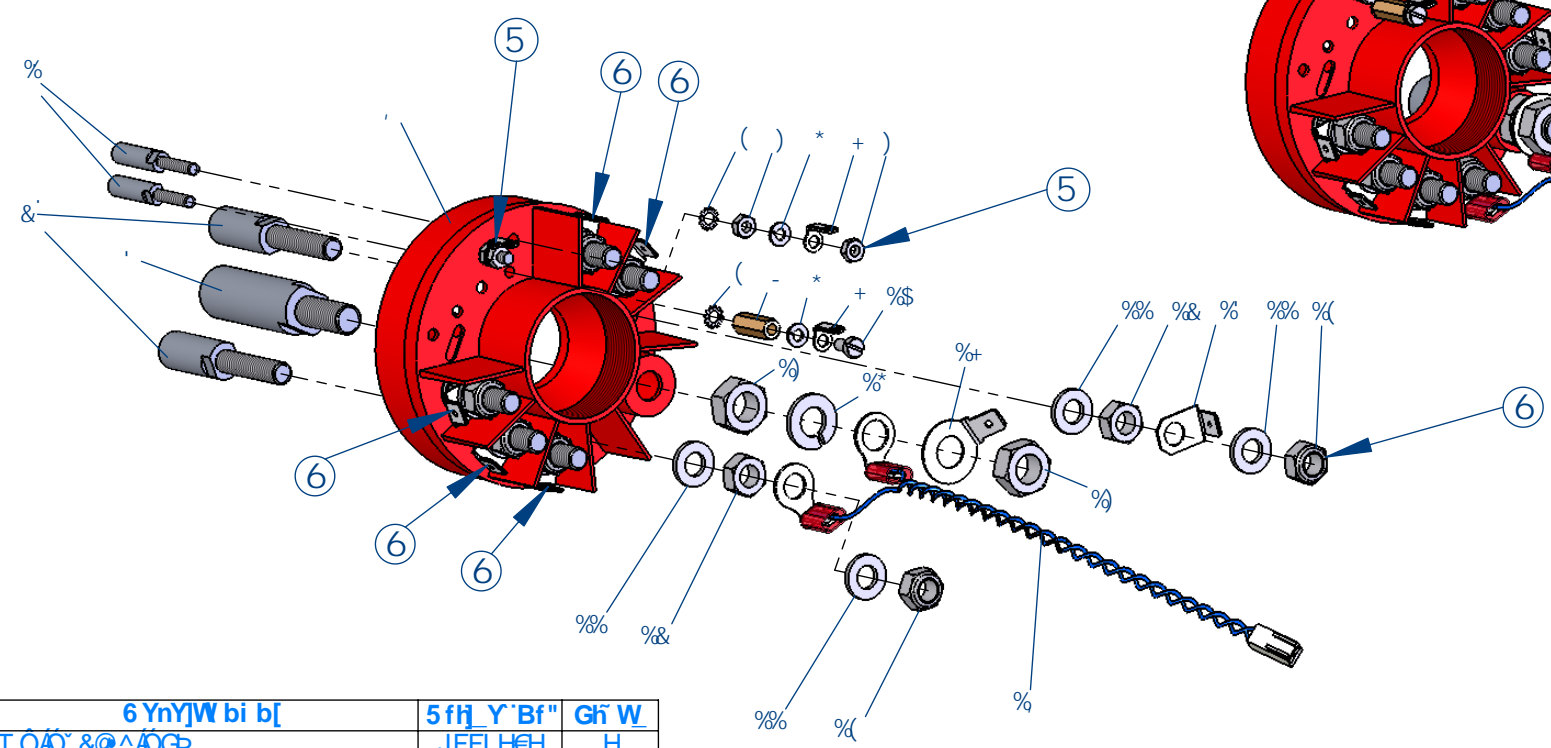
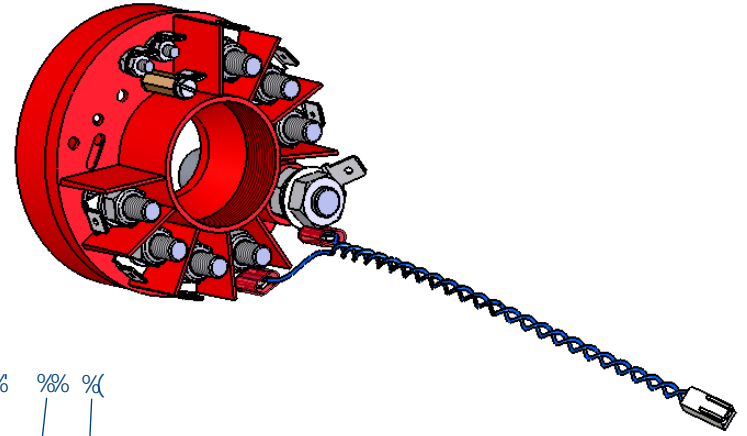

Bf"	6 YnYjW bi b[5fh_Y'Bf"	Gh W
F	T OAO' &@^AOGp	JFFI HGh	H
G	T OAO' &@^AOI p	JFFI HG	I
H	T OAO' &@^AOI p	JFFI HG	F
I	Za@ •&@ã^&H	Jl FGfI	H
I	T`æ!AT H	Jl Ffëëë	I
I	Øã^!iã * &H	Jl Ffëë	H
I	Uc&: } *^&I Jëë	JFFI I ëë	H
I	S[} cãæê *^! &XSWUG	Jl Fëfëf	F
J	Öãæ : ä[: ^) &YI AT Hã } ^) A F{ {	Ji Fi ëë	F
Fë	Z`S[&U&@æ à^AT Hçl AÖI I &XZ	Jl Fëëë	F
FF	Öãæ * &@ã^&I	Jl FGëëH	FI
FG	T`æ!AT I	Jl FfëëH	I
FH	Uc&: } *^&I JYëë	JFFI I ëf	I
FI	Uç]] { `æ!AT I	Jl Ffëfë	I
FI	T`æ!AT I	Jl Ffëë	G
FI	Øã^!iã * &I	Jl FGëfF	F
FI	Uc&: } *^&I JpðI ëë	JFFI I ëG	F
FI	Sã^!&X> } ä` } *	Jl FëfëG	F

I B @GGC H: 9FK 69 GD97 ÷ 98.
8-A 9BGC BG5F9-B A @A 9HFG
G F: 57 9: B <.
HC @F 5B7 9G
@B 95 F.
5B: I @5 F.

	B5A 9	Gp B5H F9	85H9
8F5K B	GwUi Yf5"		&+"\$&"&\$\$,
7 < ? fB			
5DDJ fB			
A ::			
E "5			A 5Hf 5@
			b]M hXYZ'

8%I F 5B8 6F95? G<5FD 98: 9G	8C BC HG7 5 @8F5K B;	F9J GCB
b["5 bhc b'GWc hY]hbYf; a V<		
Dfc Y_h J ? I D&		
HY]' 5		
6YgWfY]i b[5(
N gJa a YbVUi J ? I D&		

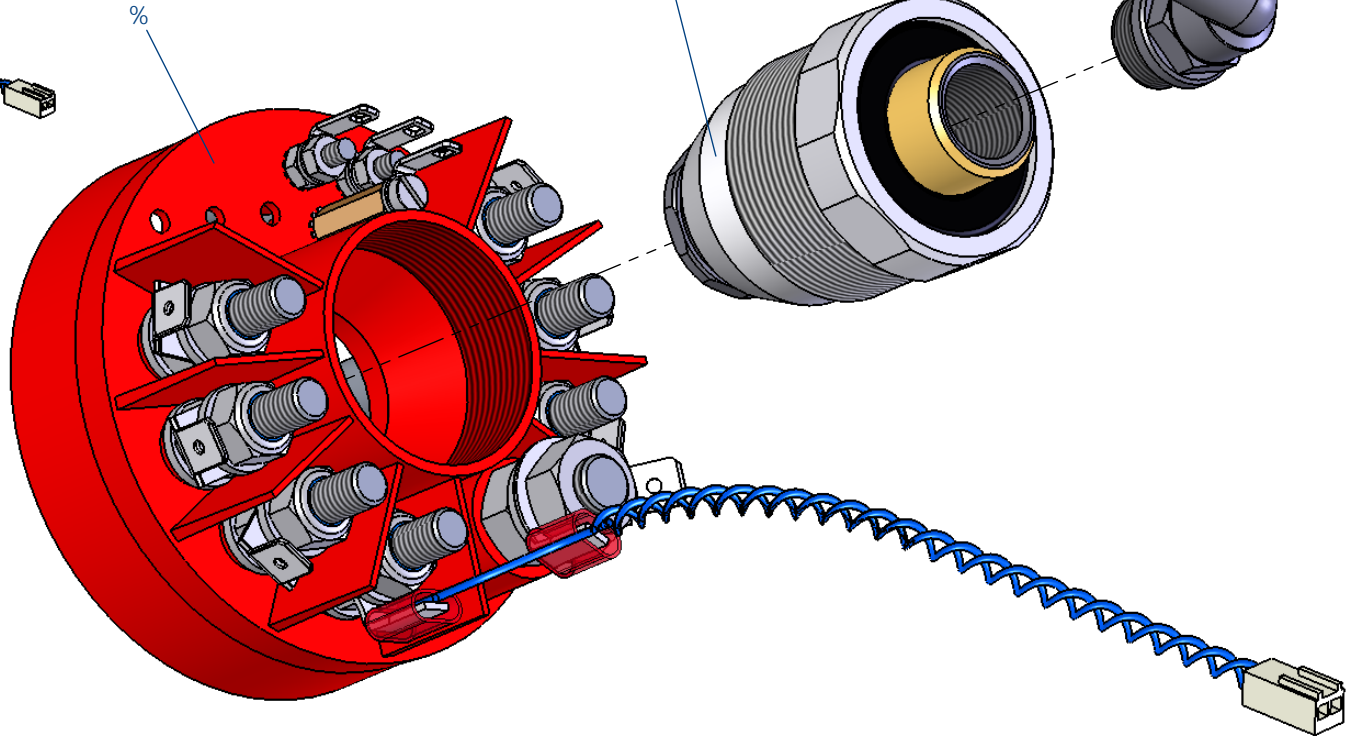
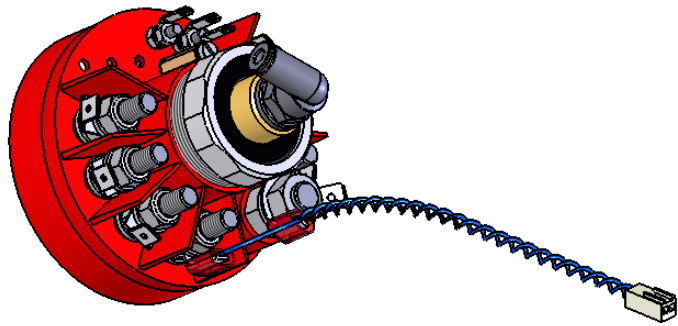

I B@GGC H:9FK -69 GD97 ÷98.
 8-A 9BGC BG5F9-B A @@@A 9HFG
 G F: 57 9: B-G<
 HC @9F5B7 9G
 @B95F.
 @5B: 1 @5F.

896I F 5B8
 6F95? G<5FD
 98: 9G

8C BC HG7 5@8F5K B:

F9J GCB

Bf"	6 YnY]W bi b[5 fh]_Y' Bf"	Gh W
F	VãáÉ	Ë	F
G	Ó\^ { • -@æã ç!	Ë	F
H	ŠËÜç & ç! •&@æ à` } * Á { { Á ÖFÉ @ÜËâ *	JHfëëH	F

	B5A 9	G: B5H F9	85H9
8F5K B	G\WUi Yf5"		&+"\$&"&\$\$,
7 <? Æ			
5DDJ Æ			
A ::			
E "5			A 5H9F-5@
			b]M\hXYZ'

þ["5 bhc b'GW\c thY]hbYf; a V<
 Dfc Y_h
 J ?I D&
 H\Y'.
 HY]'6
 6Yg\W\Y]i b[.
 N gJa a YbVUi 'J ?I D&
 5(

K 9: <H'

A UegUV. %%

6Uth) #%\$

5

5

6

6

7

7

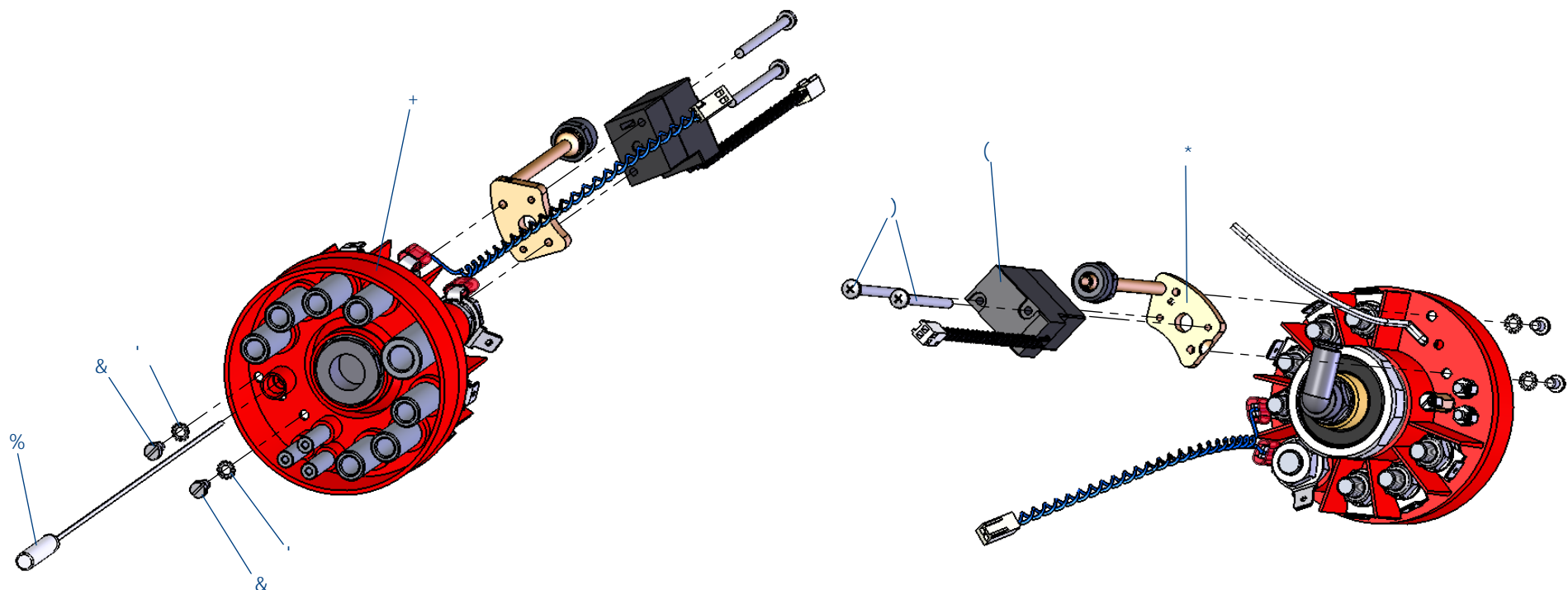

Bf"	6 YnY]W i b[5 fh_Y`Bf"	Gh W_
F	Ü^ä•^)*[!AT^ä!AT S#EÄ Öé î OË €€Y	JFFG €€	F
G	T Hç Á^Z`S[ÁU&@æ à^Á ÖP I I XZ	Ji F€€€	G
H	ZæQ •&@ ä^ÁH	Ji F€€í	G
I	T æ } ^ç^} çÄFGÖÖÁÇÉ Y	Ji F€€é	F
í	T æ } ^ç^} çÄU&@æ à^Á T ÇÉ ç I	Ji F€€é	G
î	T æ } ^ç^} çÄZæ ç!	Ji F€€é	F
ï	V^äO	€€	F

I B@GGC H:9FK 69 GD97 ÷98.
8 A 9BGC BG5F9 B A @A 9HFG
G F: 57 9: B 6<.
H C @F 5B7 9G
* @B 95 F.
** 5B: I @5 F.

: B G<.
896I F 5B8
6F 95? G<5FD
98: 9G

8C BC HG7 5@8F5K B; F9J €CB

⊕["5 bhc b'GWc hY]hbYf; a V<

Dfc Y_h
J ?I D&

HV.
HY] 7

6YgWY]i b[.
N gJa a YbVUI 'J ?I D&

5(

5

5

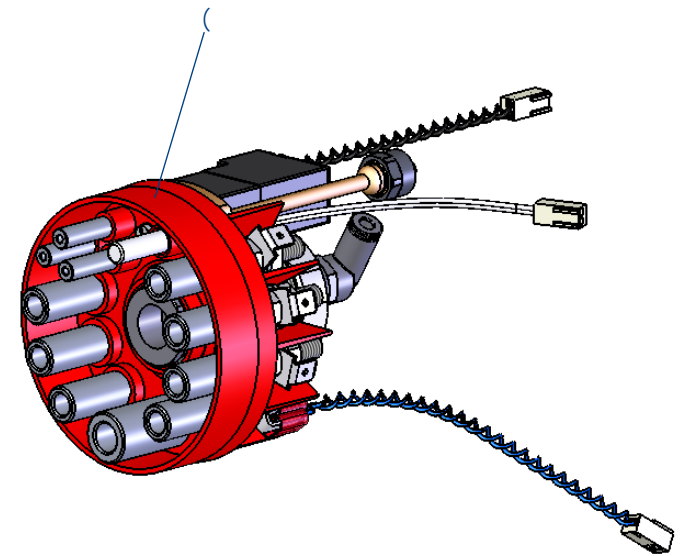
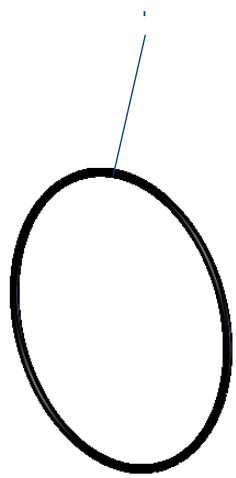
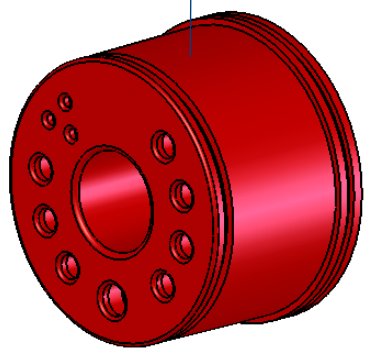
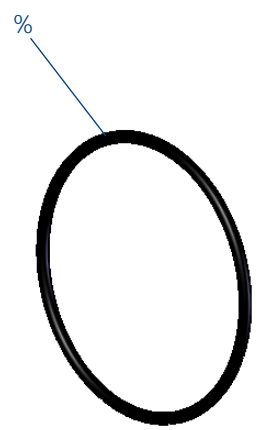
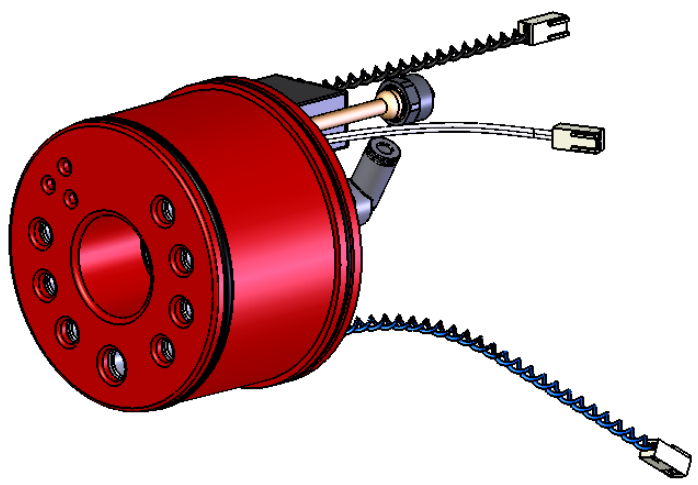

6

6

7

7

I B@GGC H:9FK 69 GD97 ÷98.
 8-A 9BGC BG5F9-B A @A 9HFG
 G F: 5 7 9: B 6<.
 HC @F 5B7 9G
 !@B 95 F.
 ""5B: 1 @5F.

:B-G<.
 896I F 5B8
 6F95? G<5FD
 98: 9G

8C BC HG7 5@8F5K B;

F9J 6CB
 b["5 bhc b'GWc hY]hbYf; a V<

Bf"	6 Yn]W i b[5 fh_Y`Bf"	Gfi W_
%	C!F]b[]X*) ' I'X&	- ' % \$\$(<	%
&	9]bdfYgg[\ \} i gYJ?I D&	-) %\$%&	%
'	C!F]b[]X+, ' I'X&	- ' % \$\$)	%
(HY]`7	!!	%

B5A 9	Gp B5H F9	85H9
8F5K B	GWUi YF5"	&+"\$&"&\$\$,
7 <?7B		
5DDJ B		
A ::		
E "5		
		A 5H9F 5@
		b]W hXYZ'
		K 9p <H'

Dfc Y_h	J ?I D&	
HV.	HY]`8	
6YgWfY]i b[.	N gJa a YbVUi ' J ?I D&	5(

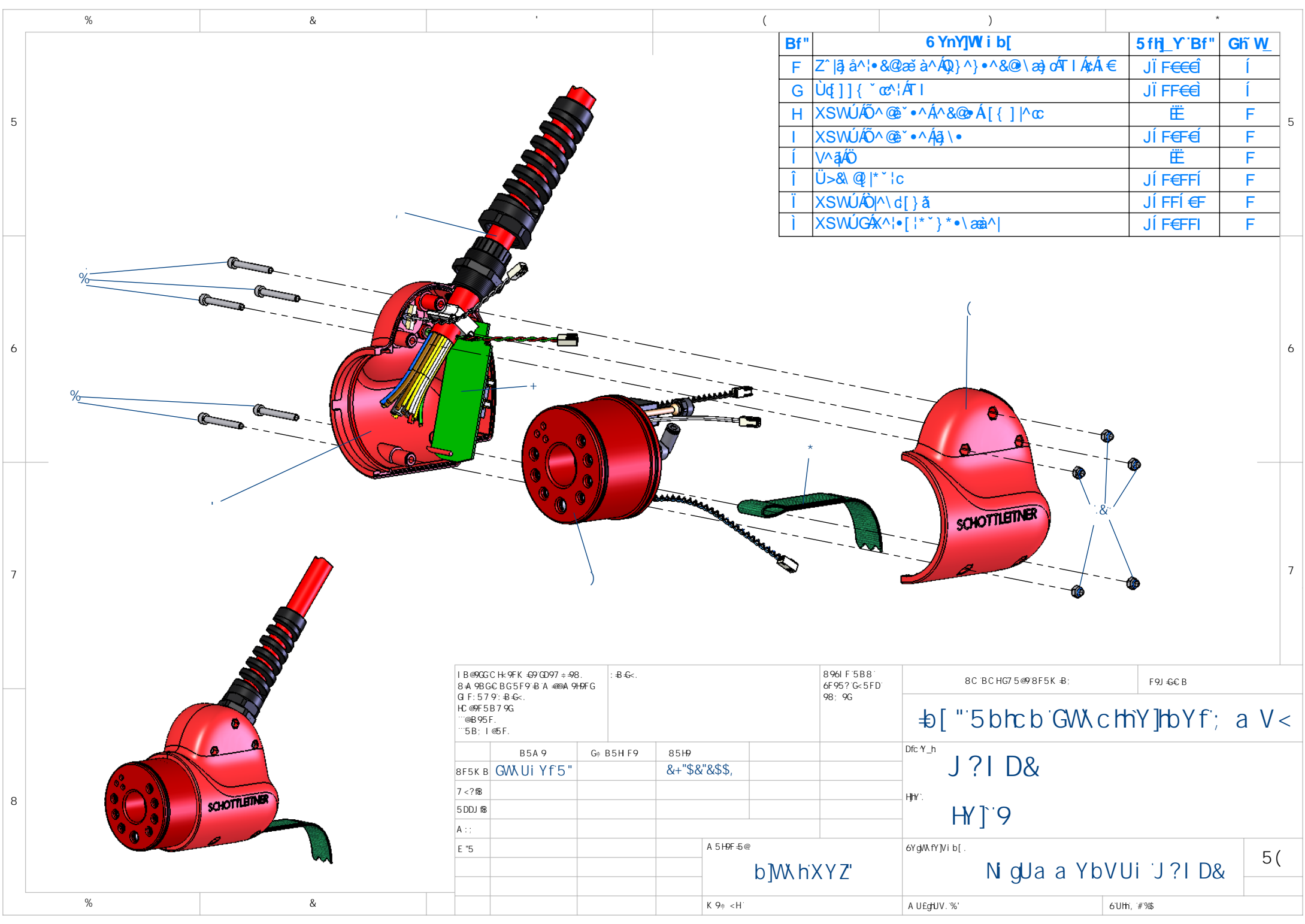

Bf"	6 YnY]W i b[5 fh_Y`Bf"	Gñ W
F	Z` ã á!•&@æ à^A}^}•^&@\æ dT A€	Jí Fëéí	í
G	Ùq]]{`~æ!ÁI	Jí FFeéí	í
H	XSWÚÔ^@~•^A^&@Á[{} ^c	Ë	F
I	XSWÚÔ^@~•^Aq\•	Jí FFe-éí	F
Í	V^qÖ	Ë	F
Î	Ü>& @ ^*~ c	Jí FFFí	F
Ï	XSWÚÔ^ \d[}ã	Jí FFí €	F
İ	XSWÚG^X^ \[!^*~}*•\ææ^	Jí FFFí	F

I B@9GC H:9FK 69 GD97 ÷98. 8 A 9BGC BG5F9 B A @A 9HFG G F: 5 7 9: B 6< H: @F 5B 7 9G * @B 95 F. ** 5B: 1 @5 F.			: B 6<.		8 96I F 5B8 6F 95? G<5FD 98: 9G		8C BC HG7 5 @8F5K B;		F9J €C B		
B5A 9			G: B5H F9		85H9		b["5 bhc b`GW c hY]hbYf; a V<				
8F5K B GWUi YF5"					&+"\$&"&\$\$,		Dfc Y_h J ?I D&				
7 <? 8							HY]'9				
5DDJ 8											
A ::											
E "5					A 5H9F 5@		6YgWY]Vi b[.		N gJa a YbVUi `J ?I D&		
					b]W hXYZ'		5(
					K 9: <H'		A UegUV. %'		6Uth. #%\$		

